

# HT-80

Three-knife Trimmer

**Swing knives allow accurate cutting and beautiful finishing.**





## The HT-80 automated three kn can be used off-line or in-line efficient book production.

### Automated Set Up

Most sections can be set up automatically by inputting the untrimmed size and finished size into the intuitive color touch screen for quick and accurate change over.

### Servo Motor Driven

Servo motors are employed for accurate positioning of the book block. Also, through the touch panel screen, the pressure of the press is adjusted automatically so that no mark remains on the trimmed book. Oil less control for environmental friendly operation.

### High Quality Finish

Rigid construction and heavy-duty mechanisms ensure consistent, accurate quality.

### Book of one Production

Books of the same size but different thickness can be trimmed at the same time, for true book of one production.

To handle this production you can choose either one of operation;

1. input maximum book block thickness and the system will trim within the inputted thickness range continuously.
2. the optional TD-80 will measure the thickness of each book before trimming and the press plate waiting position will automatically set for faster production.

### In-line Production

System can be placed in-line with Horizon perfect binders BQ-500, BQ-480, BQ-470, SB-07, SB-09V or SB-09S for efficient book production.

### Bindery Control System

The HT-80 can be networked with the Horizon pXnet Bindery Control System which can plan jobs, collect production data across the bindery, and even interface with an existing workflow for automated JDF set-up.



HT-80 + HR-80

### 1 Touch screen for Easy Operation



Most trimmer sections can be set up automatically by inputting the untrimmed size and finished size into the intuitive color touch screen. Up to 200 job setups can be memorized for repetitive or special jobs.

### 2 Jogging Section



Thanks to Servo motor drive, jogging frequency and stroke can be adjusted for highly accurate positioning and a consistent trimming result.

### 3 Clamping Section



Servo motor driven pressing mechanism ensures strong pressure (maximum 10kN pressure) to achieve accurate trimming result. Pressure can be adjusted automatically to avoid marking the book.

## Three-knife trimmer for fast,



### 4 Trimming Section

Swing knife movement ensures sharp and accurate trims for a clean finished book. Trimming dust removal is ensured with unique guide movement design. Various sizes of press and cutting plates are available option to handle a wide range of book sizes.

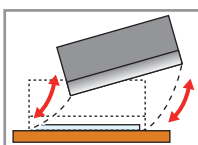

Swing Knife Movement

### In-line book production with intelligent automation

The HT-80 automated three-knife trimmer can be connected with the automated BQ-500 perfect binder for in-line book production efficiency.



#### Option

### SS-800

The SS-800 accumulates the bound books and transports them to the cooling conveyor. Settings such as the number of stacked books can be set through the touch panel of the BQ-500. (When the BQ-480 or BQ-470 is connected, the touch panel of HT-80 is used for setting the SS-800.)



#### Option

### Bookblock Thickness Detector TD-80

Before trimming, the thickness of each book is measured. According to the measured thickness, the press plate waiting position changes automatically for production efficiency.

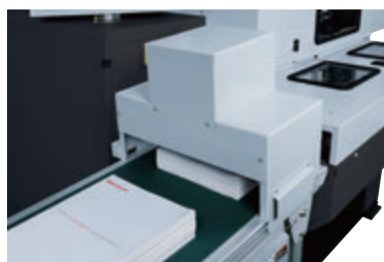

#### Option

### Cooling Conveyor

Bound books are transported from the binder to the trimmer by use of the conveyor which is equipped with intermittent conveyor control system. This conveyor ensures sufficient cool time even in a small foot print. Various layout can be arranged depending on space requirements.

\*In-line production requires at least 3m (9.9 ft) conveyor for cooling.  
\*For PUR binding, 6m(19.8 ft) or longer conveyor is recommended.



## HT-80 Major Specifications

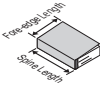
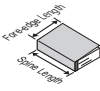



Untrimmed Book Size		<b>Spine Length x Fore-edge Length</b> Max. 330 x 330 mm or 13" x 13" 350 x 330 mm or 13.78" x 13" (When Using the Optional C-80L) Min. 145 x 105 mm or 5.71" x 4.135"
Finished Book Size		<b>Spine Length x Fore-edge Length</b> Max. 300 x 300 mm or 11.81" x 11.81" 340 x 300 mm or 13.385" x 11.81" (When Using the Optional C-80L) Min. 139 x 99 mm or 5.475" x 3.9"
Trim Width	Top and bottom: Max. 30 mm or 1.18" each Fore-edge: Max. 30 mm or 1.18"	
Trim Height	1 to 51 mm or 0.04" to 2"	
Standard Size Trimmed by Standard Accessory	A4, 8.5" x 11", A5, 5.5" x 8.5"	
Clamp System and Pressure	Servo Motor 4 kN to 8 kN (10 kN depending on Condition)	
Production Speed	400 to 1,000 cycles per hour	
Voltage / Frequency	3-phase 200 to 230 V, 50 or 60 Hz 3-Phase 380, 400, 415 V 50 Hz (Step down to 200 V by Transformer)	
Machine Dimensions	W1,610 x D2,610 x H1,515 mm or W63.4" x D102.8" x H59.7"	

## Compressor Major Specifications (To be arranged locally)

Type	Connected to off-line, SS-80, TD-80	Connected to SS-110
Rated Output of Prime Mover (Reference)	50 or 60 Hz, 1.5 kW	50 or 60 Hz, 2.2 kW
Minimum Required Pressure	0.6 MPa or more	0.6 MPa or more
Minimum Discharge	160 Liters per minute	260 Liters per minute

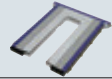
\*Use the compressor with this specifications.

## Accessories

Cutting plate	Model	Trimming size
	CP8-FS	Top-bottom : 139 to 218 mm or 5.475" to 8.58" Fore-edge : 99 to 300 mm or 3.9" to 11.81"
	CP8-FM	Top-bottom : 218.1 to 300 mm or 8.585" to 11.81" Fore-edge : 99 to 300 mm or 3.9" to 11.81"
Press plate	Model	Trimming size
	PP8-A5 (Inch PP8-55x85)	A5, 5.5" x 8.5"
	PP8-A4 (Inch PP8-85x11)	A4, 8.5" x 11"

\*Besides those shown above, other cutting/clamper plate sizes are available.

## Options

Stack/Conveyor section	Stack Stream unit (connected to BQ-500 / BQ-480 / BQ-470)	SS-800	
	Stack Stream unit (connected to SB-09V / SB-09S / SB-07)	SS-110	
	Selection	1m (3.3 ft) Conveyor	CV8-1
		2m (6.6 ft) Conveyor	CV8-2
		3m (9.9 ft) Conveyor	CV8-3
		Curve Conveyor	CV8-L
	Cooling Conveyor (connected to SS-110)	-	
	Cooling Conveyor guide	HCG-80	
	Stepstool	KB-80	
Three-knife trimmer section	Selection	1m (3.3 ft) Conveyor for manual feed (stand alone)	HC-80
		Roller Conveyor for manual feed (stand alone)	HR-80
	Wide Pusher	WP-80	
	Bookblock Thickness Detector	TD-80	
	Silicon Spray unit	SSP-80	
	Chip Extractor unit	TB-100	
	Fore-edge cutter (L)	C-80L	
Clamper plate / Cutting plate	Each size		

\*The machine design and specifications are subject to change without any notice.

\*Specifications may vary depending on the job, paper quality, environmental influences, and various other factors. Please do a test run before starting production.

## Machine Dimensions (Unit : mm or inch)

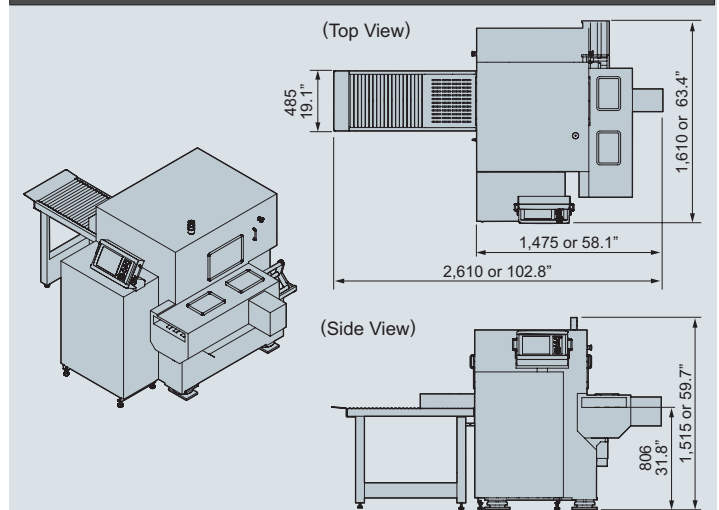

## BQ-500 + HT-80 in-line configurations (Unit : mm or inch)

### Layout 1 : Straight Configuration (3m or 9.9ft)

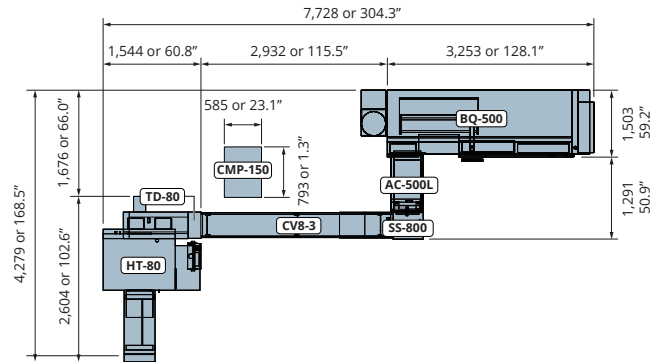

### Layout 2 : L-shape configuration (3.7m or 12.2ft)

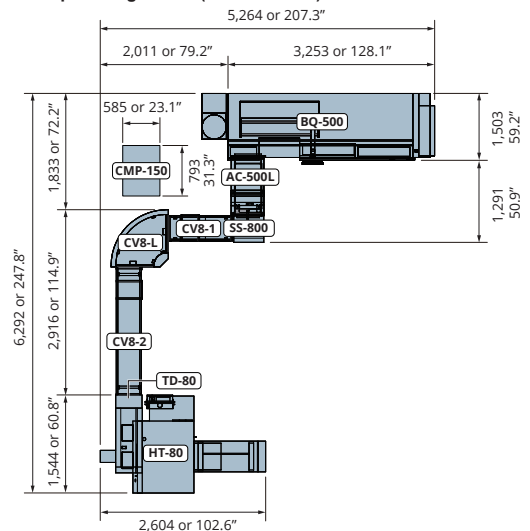

## Perfect binder which can be connected to HT-80

- BQ-500
- BQ-480
- SB-470
- SB-09V
- SB-09S
- SB-07

\*Available by Special Order.

Distributed by

## HORIZON INTERNATIONAL INC.

510 Kuze Ooyabu-cho, Minami-ku, Kyoto, 601-8206, Japan Phone : +81-(0)75-934-6700, Fax : +81-(0)75-934-6708, www.horizon.co.jp